

PROJECT:	TYPE:
VOLTAGE:	COMMENTS:

SV150T

SPECIFICATIONS FEATURES

UL Listed:

for Wet Locations
 UL file No. E202257

Electrical Rating:

120 VAC, 60 Hz / 3 A (start up)
 120 VAC, 60 Hz / 1.8 A (running)
 220-240 VAC, 50 Hz, 3 A (start up)
 220-240 VAC, 50 Hz, 1.2 A (running)

Lamp:

- 150 watt metal halide - 4,000K
- 10,000 hours average life

Fiber Capacity:

- 550 fibers maximum w/.75MM fibers
- 288 fibers - Ultra SideGlow 1mm
- 756 fibers maximum (upgrade) .75MM
- 435 fibers maximum - Ultra SideGlow (upgrade) 1MM

Power Consumption:

200 watts max.

Storage Temperature:

-40°F to 140°F (-40°C to 60°C)

Ambient Operating Temperature:

-20°F to 110°F (-29°C to 44°C)

Motors: 1RPM motor

Dimensions:

9.5" x 9.5" x 20"
 241MM x 241MM x 508MM

Weight:

21 lb (9.5 kg)

Material/Finish:

UV stabilized materials, water, corrosion and chemical resistant

Mounting / Installation:

Surface or burial mount up to area below fan location.

Standard Features:

On/off power and color wheel switch

Ventilation:

Forced ventilation 115 CFM, FAN: 20 Watts, 80,000 hrs. lamp life 6" clearance required to nearest surface. 2' clearance between each illuminator.

Upgrades:

- White only to 6 colors
- 550 - 756 fiber head
- RF controlled light source (surface)

Standards:

UL / cUL

IP Rating: 23

dB Rating: 48dbA

Warranty:

2 Year (excluding lamp)



DESCRIPTION

SV150T Tower illuminator 150 watt metal halide lamp 10,000 hour lamp life 550 strand fiber capacity. The base of the SV150T illuminator is designed for burial with the fibers, electrical and control wires concealed under the base.

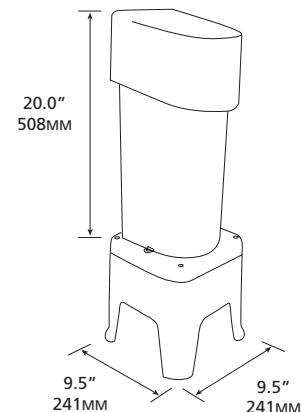

ORDERING INFORMATION

MODEL
SV150T6

120V, WITHOUT CONTROLLER

SV150T6-SI

120V, WITH CONTROLLER

SV150T6220

220V, WITHOUT CONTROLLER

SV150T6C220

220V, WITH CONTROLLER

SV150T1

120V, WITHOUT CONTROLLER -
 NO COLOR WHEEL OPTION

COLOR WHEELS

ALL UNITS COME STANDARD WITH THE **6S-HC** - 6 COLOR STANDARD CONTROLLED COLOR WHEEL EXCEPT FOR THE SV150T1 WHICH COMES WITHOUT A COLOR WHEEL OPTION

NOTE: Refer to pages 50-51 for detailed color wheel information

SV150T6

Ordering Example: **SV150T6**